

DYNAFOAM[®] BOARD

XPS HEAT INSULATION PANELS

"Proper insulation, profitable insulation"

- Reduces energy consumption,
- Provides thermal comfort,
- Provides a healthy life,
- Reduces the initial investment and operational costs,
- Contributes to environmental protection.

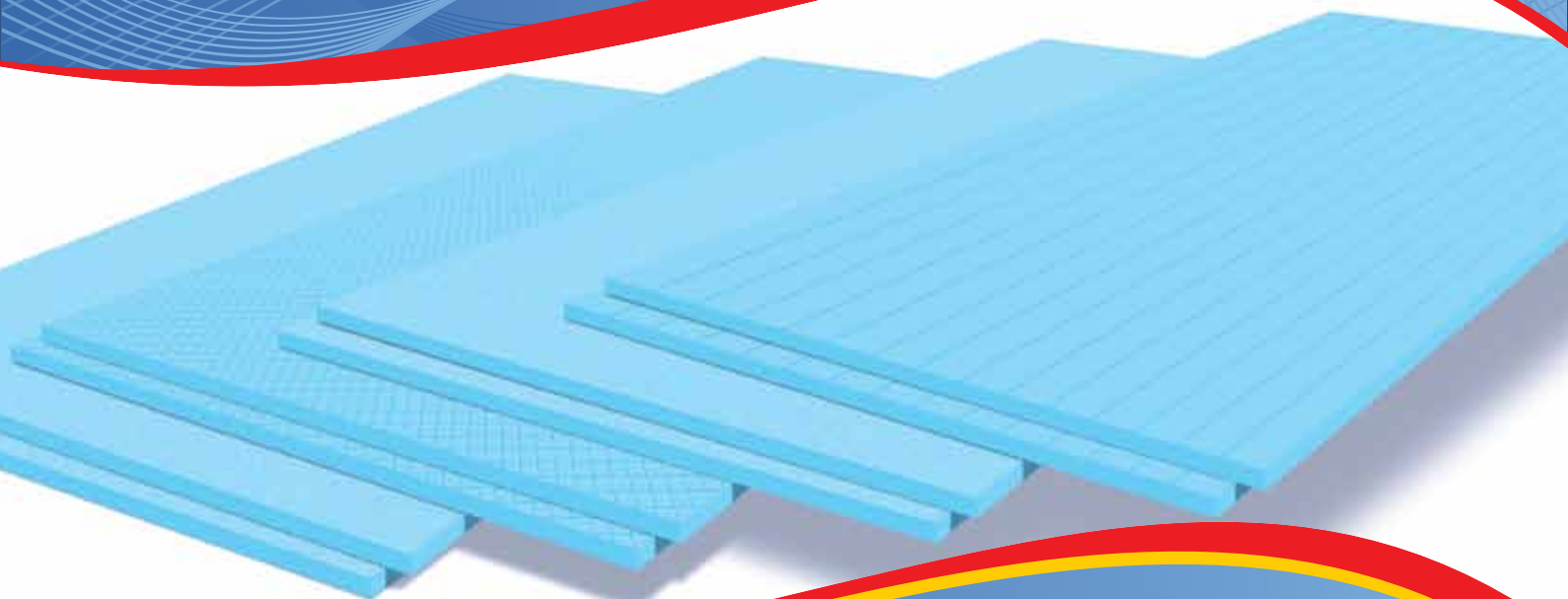

CFC-HCFC
FREE

RoHS



dinamik[®]

A dynamic solution in insulation

With its 20 years of experience, Dinamik undertakes the duty of being one of the most reliable solution partners of the shareholders and moves toward the better ambitiously. Being a solution partner that always focuses on the most qualified with the products it produces and services it presents, Dinamik adds a new investment to the current ones every day.

- *Dinamik was established in 1991.*
- *It began functioning in the field of insulation in 1993.*
- *It established "Insulation Consulting Centers" in Izmir and Denizli in 1997.*
- *It produced various accessories used in Insulation between 1993 and 2003.*
- *It started industrialism with an investment decision in 2003.*
- *It put in use the Polyethylene Thermal Insulation Foam facilities manufacturing with the brands Climaflex and Dynaflex, which has a closed space of 2500 m² on a 5000 m² land in Izmir/Tire in July 2004.*
- *It started importing foam rubber, HVAC tapes and rock wool thermal insulation products in 2004.*
- *In 2005, it set up the ISO 9001-2000 Quality Management System and documented it.*
- *It started exporting in 2005 and was granted with the award "the firm that realized the highest increase in exporting" in 2008 by Aegean Region Chamber of Industry.*
- *Establishing the second PE line in 2006, it began production towards packaging industry with the brand DynaProfil.*
- *It doubled the factory storage capacity in 2007 and built a logistics warehouse that has a closed space of 2600 m².*
- *It entered the sanitary insulation market in 2008 with its own brand Dynaflex Rubber with foam rubber products and marketed the first aluminum cladding coated foam rubber Dynaflex Rubber PVC AL-CLAD manufactured in the facilities in Tire.*
- *It began manufacturing HVAC Tapes in 2008 by investing in the Slicing, splitting and lamination equipment.*
- *It put Acoustic Foam products on market in 2008 with DynaAkustik brand.*
- *Constructing the third building with a 3000 m² closed space in 2009, it carried the converting equipment such as lamination, slicing and splitting to this building.*
- *It activated a new line, which would produce Dynafoam Polystyrene products that are used in ground and inner wall insulation in 2010 with the support from Izmir Development Agency.*
- *It decided to invest in XPS Foam manufacturing used in Thermal Insulation at the end of 2010 and started the construction of the fourth factory building that would have a 5000 m² closed space on a 10000 m² land.*
- *In 2011, it established ISO 14001:2004 Environmental Management System and documented it.*
- *In July 2011, it opened Warehouse and Sales Office in Istanbul /Dudullu and,*
- *It put in use XPS manufacturing facilities following polyethylene, polystyrene and converting facilities by August 5th 2011.*

Dinamik decided to manufacture XPS thermal insulation panel at the end of 2010 and started acting in line with this decision. In such a short time as 7 months, Dinamik completed construction investment, machine supply and assembly and started production at the designated date and marketed the products Dynafoam Board and MantoPlus brands. Plated, plain, rough, rough – slotted and patterned XPS thermal insulation products in 2 cm and 8 cm intervals are produced in Dynafoam manufacturing line, which is the newest facility established with modern technology in our country. With superior properties, broad variety and product quality, Dynafoam Board is the candidate to become the first preferred brand by investors, designers and implementers.

Dinamik, established in Tire Organized Industrial Zone and manufacturing on a 14000 m² closed space and 35000 m² space in total, gives priority to quality in all products put into market and follows new requirements closely while working continuously in order to create new solutions. With an experienced staff and human-focused working system that foresees the needs; Dinamik looks towards the future with trust and is determined to continue its investment attempt that has been ongoing since 2004 with the new investments to be done in the upcoming years.

We invite you to collaborate with us in supply of insulation products and see our firm as the solution partner.

You will have several reasons to prefer us:

- **20 years of experience,**
- **The advantage of being the manufacturer,**
- **Technical knowledge and support,**
- **Detailed manufacturing,**
- **More than 4000 material items half of which are its own production,**
- **Experience in practice,**
- **Material delivery out of stock,**
- **Service approach suitable to ISO 9001:2008 Quality Management System and**
- **Friendly manner not limited with sales. . .**



INSULATION AND THERMAL COMFORT WITH DYNAFOAM BOARD

Thermal conditions in closed areas directly affect the comfort and health of people living in those settings. People's work efficiency is mostly determined by the conditions of the setting they are in. The thermal conditions of the work setting affect people's physical and mental pace of production. It is found out that extremely cold or hot settings reduce work efficiency. Moreover, health problems arising from extremely cold settings cause loss in workforce and related health expenditures. Also, it is shown that when temperature in indoor space is too high or low, work accidents occur.

In order to prevent these, it is needed to provide thermal comfort in buildings. The temperature gap between the temperature in the setting and internal surface temperature of the wall should be decreased to ensure thermal comfort. The more this gap is, the less the comfort is. This gap needs to be 3°C at most to have a comfortable setting. In case internal surface temperatures are low, the movement of heat towards colder surfaces creates undesired airstreams. These airstreams decrease comfort and cause diseases. In contrast to what is assumed, to have a high level of indoor space temperature doesn't provide comfort. The important thing is that the average temperature in all indoor surfaces surrounding the indoor space should be close to the temperature of the setting because the temperature one feels is not the temperature of the settings but the average of internal surface temperature and setting's temperature. One can live comfortably and produce in such settings. The sensible temperature can be calculated via the below formula:

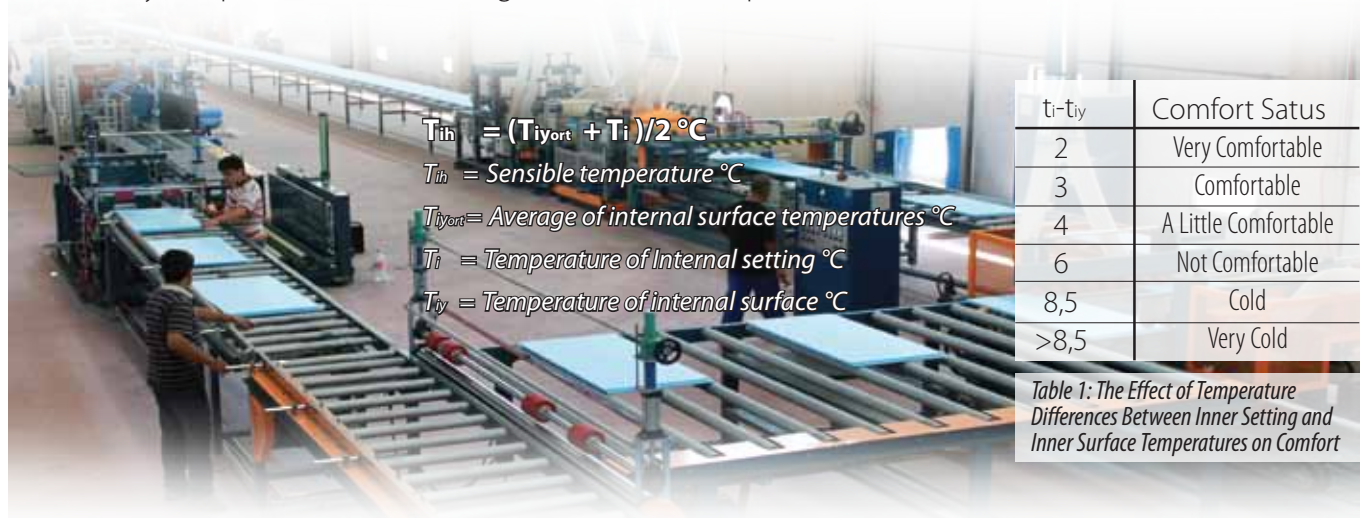

$T_{th} = (T_{iyort} + T_i) / 2 \text{ } ^\circ\text{C}$
 $T_{th} = \text{Sensible temperature } ^\circ\text{C}$
 $T_{iyort} = \text{Average of internal surface temperatures } ^\circ\text{C}$
 $T_i = \text{Temperature of Internal setting } ^\circ\text{C}$
 $T_{iy} = \text{Temperature of internal surface } ^\circ\text{C}$

t _i -t _{iy}	Comfort Satus
2	Very Comfortable
3	Comfortable
4	A Little Comfortable
6	Not Comfortable
8,5	Cold
>8,5	Very Cold

Table 1: The Effect of Temperature Differences Between Inner Setting and Inner Surface Temperatures on Comfort

A comfortable life for human beings may be possible in settings with a temperature of 20-22°C and 50 % relative humidity. In winter months, the external environment temperatures range quite below 20°C while in summer months temperatures are above 20°C. Heat is a type of energy and as per the second law of thermodynamics heat is transferred from high temperature to low temperature. Therefore, in winter, there are energy losses and in summer there are undesired energy gains. In order to ensure the desired comfort setting in the building, it is required that the heat lost should be compensated with a heating system in winter and the heat gained should be removed from indoors with a cooling system in summer. Energy is consumed both for heating and for cooling. Limiting the losses and gains in a structure means reducing the amount of energy for cooling and heating purposes and only with a good **INSULATION** an efficient use can be provided.

The process made for limiting heat losses and gains in buildings is called **“thermal insulation”**. Technically, thermal insulation is performed in order to reduce the heat transfer between two settings with different temperatures.

In order to ensure heat insulation in buildings, thermal insulation should be done in:

- External walls,
- Glass and Woodwork,
- Roof and floor coverings,
- Installation pipes,
- Ventilation ducts,
- Steam transfer pipes,
- Sections contacting land and sections separating floors
- Walls facing not heated areas as garage or storage.

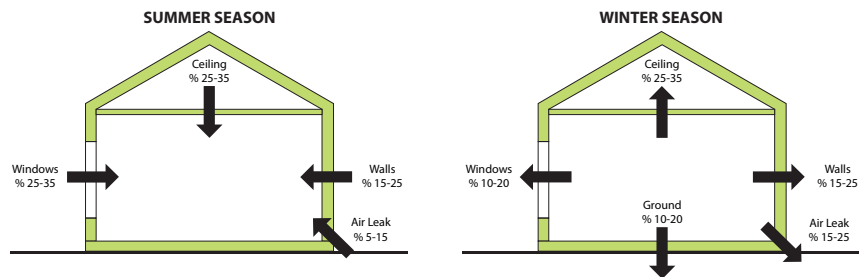

The average heat losses and gains occur 25 % in windows, 20 – 25 % in ceilings and roofs, 10 - 20 % in floors and floor coverings and 15 – 25 % in walls and 5 – 15 % with air conditioning.

The same level of comfort can be ensured by using 25 – 50 % less fuel when buildings are insulated properly. Basic sections like doors, windows, walls and roof, which separates the inner part of the building from the outer environment, ensure that the building is kept cool in summer and warm in winter. Several methods and materials are used throughout the world for ensuring a better building insulation.

Recent regulations, standards and legislation in our country with regards to thermal insulation have made heat insulation obligatory. Thanks to its high performance in thermal insulation, **Dynafoam Board** XPS heat insulation material satisfies the users and the implementers. Presented with the slogan “Proper Insulation, Profitable Insulation”, **Dynafoam Board** XPS insulation panel is an ideal product that can be used in roof, wall, floor coverings and in different special practices.



ENVIRONMENT AND ENERGY SAVING WITH DYNAFOAM BOARD

As a result of the fact that energy needs have increased all around the world and efficient energy is not used, air pollution increases. This increase in air pollution appears as global warming and climate changes. The global warming threat and reducing air pollution are among the most important issues of today.

Although we do not clearly see the tragic results of global warming like the disasters experienced in Japan and Chernobyl in the near future, in fact nature always shows us the approaching danger. The floods in the middle of summer, melting glaciers, farming lands becoming deserts, hunger in countries like Kenya or Somali show us that we must fight with global warming.

Fuel saving that can be obtained by reducing heat losses in winter and heat gains in summer will also ensure a reduction in greenhouse gases diffusing in the atmosphere. While some fuels like coal and petrol visibly cause air pollution, on the other hand they cause global warming and related climate changes.

When fossil fuels are burnt, carbon dioxide, a colorless and unburned gas, is released. Generally, carbon dioxide that is at the lower layer of atmosphere, namely the troposphere, is important in terms of ecologic balance. As a result of the increase in energy consumption, the amount of carbon dioxide in atmosphere increases every year. As a result of this, too much amount of energy is absorbed and the temperature in atmosphere gradually increases while sunlight reaches the earth and returns back with reflection. Global warming is the result of this increase in atmosphere temperature with the effect of these gases called greenhouse gases. We may not be feeling the tragic conclusions of air pollution and global warming so close but it is necessary that the warnings of experts should be taken into account and an action should be taken. One of the major things to be done is the insulation precautions.

Thermal insulation precautions that will ensure effective use of energy will have an important role in reducing greenhouse gas emissions that cause global warming by decreasing fossil fuel consumption. Besides, thermal insulation will decrease the need for the refrigerating gases which damage the ozone layer and which are used for cooling in summer months. The decreasing energy consumption will reduce the need for electricity and hence production of electricity and the amount of fossil fuel used in production, thus gas emission.

Within this respect, Dynafoam Board XPS Thermal Insulation also contributes in environmental protection. Moreover, it is an environmentalist as no gases, the use of which are prohibited with the Kyoto Protocol, is used in its production.



DYNAFOAM BOARD FIELDS OF PRACTICE

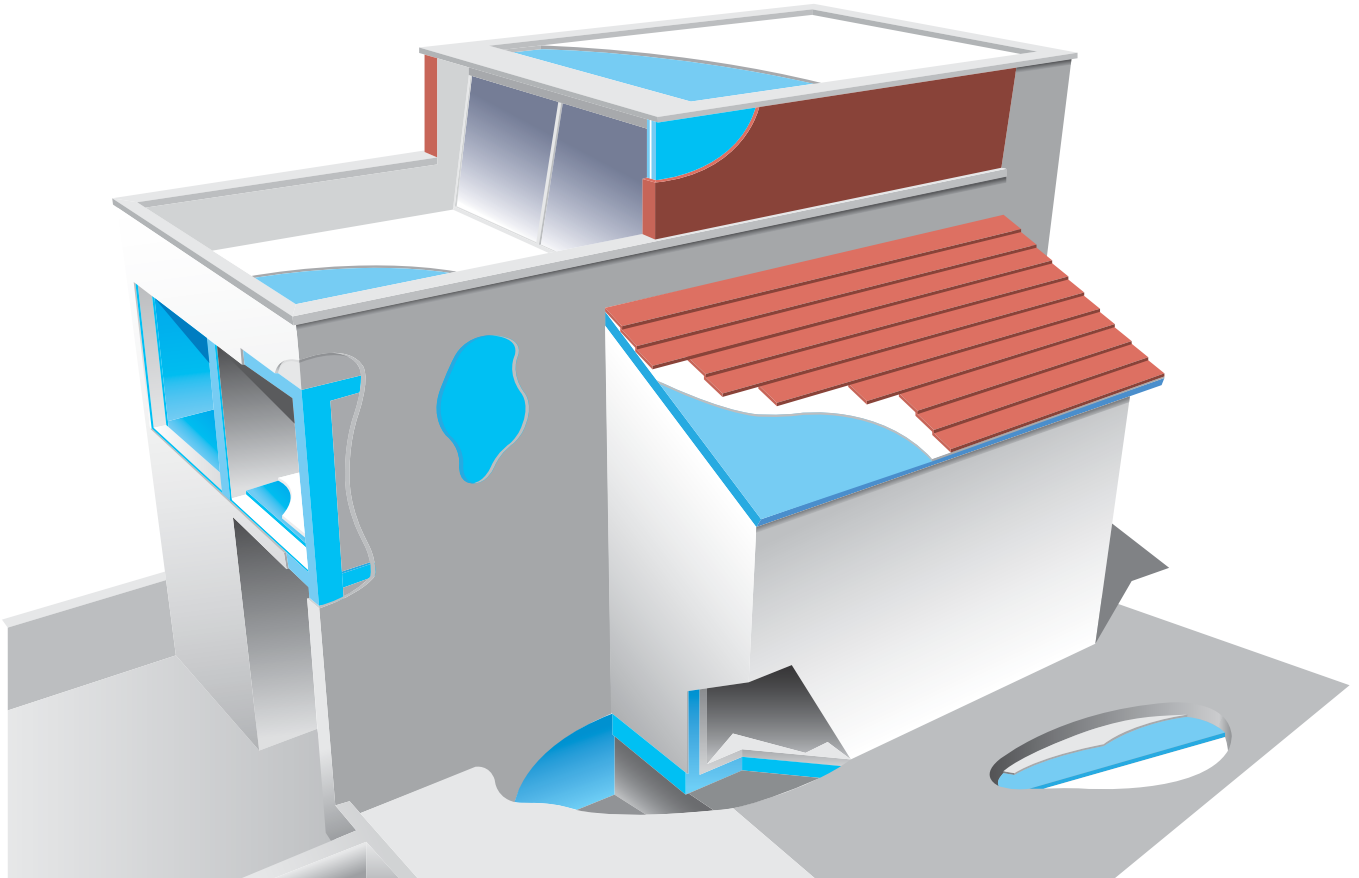

THERMAL WALL INSULATION

External Wall
Insulation

Internal Wall
Insulation

Column, Beam
Insulation

Curtain Wall
Insulation

Cavity Wall
Insulation

ROOF THERMAL INSULATION

Terrace Roof Thermal
Insulation

Jerkin-Head Roof
Insulation

FOUNDATION INSULATION

Concrete Wall
Insulation

Under Floor
Insulation

SPECIAL PRACTICES

Cold Storage
Insulation

Animal Farm
Insulation

Under Parquet
Insulation

Aluminum, Metal and
PVC Panel Practices

1- THERMAL WALL INSULATION

1a- External Wall Insulation

Jacketing (Thermal insulation) is applied on the shell surrounding the building, that is the external surface of the external wall. Since it completely covers the sides of the building, it is the most ideal insulation method. Jacketing protects the external shell of the building from thermal stress and extends the lifetime of the building and also after the heating system is closed, it ensures the continuation of comfort conditions (particularly in residences). In jacketing practices, Dynafoam Board Extruded Polystyrene Thermal Insulation Panels (XPS) are placed on the wall surface with soil cement base. Next, mechanical detection is done with insulation dowel

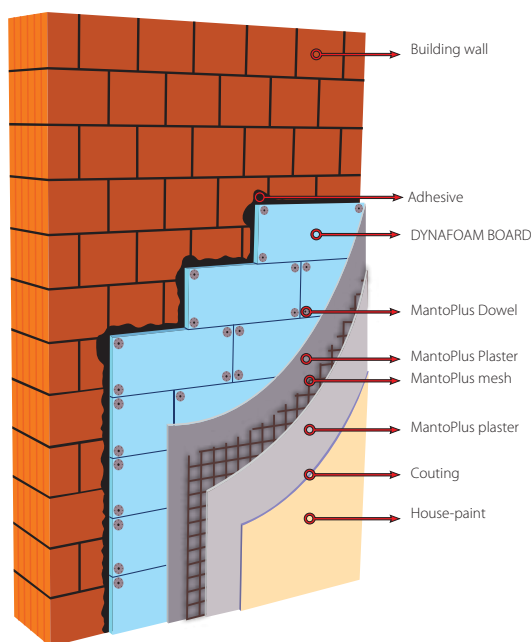

with plastic nails in a way that there are 6 for each m^2 . A thin plaster is done with the soil mixture used in sticking and glass fiber plaster mesh resistant to alkaline is applied on this mixture in a way that it covers whole wall surface. Following this application, the top of mesh is plastered again and after the plaster dries, it is painted. The moisture seen inside the building doesn't occur because water leaks from the cracks on the external surface as assumed but because of the insufficiency of wall thicknesses and because there is no thermal wall insulation. The high level of difference between indoor temperature and the temperature of building shell's inner surfaces, where no thermal insulation is done or insufficient insulation is done, also indicates the pressure difference between two settings. Partial pressure of warm indoor setting and partial pressure of cold outdoor setting are different. Due to this pressure difference, indoor air moves toward outdoors and tries to go out. When the setting air carrying vapor in it crashes cold surfaces with low temperatures, it leaves the water vapor inside to cold surfaces and this process is called **"condensation"**. Condensation causes the paint and decoration to fall down, corrupt and the formation of mold and fungi as bacteria in the setting air accumulates here. Indoor air quality gets worse and this causes illnesses.



1b – Internal Wall Insulation

Though the most appropriate method in wall insulation in terms of structure physics is external insulation, in case this is not possible, internal insulation is applied. Dynafoam Board panels stick to internal wall surface with cement or plaster based adhesive mortar. In case height is above 3 meters, panels may not be detected with dowel. After sticking joint tape on panels' connecting joints, plaster coating is directly applied on panels. If it is to be painted, it is recommended that a thin layer of satin plaster application be made.

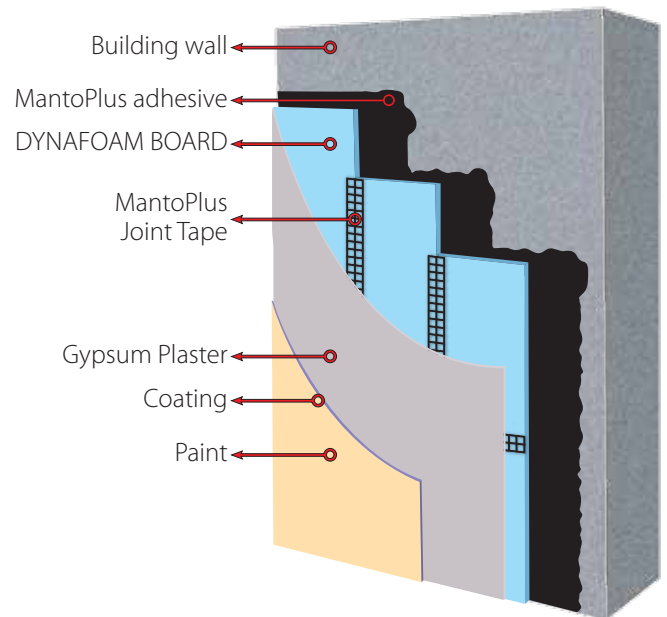

1c- Column and Beam (Thermal Bridges) Insulation

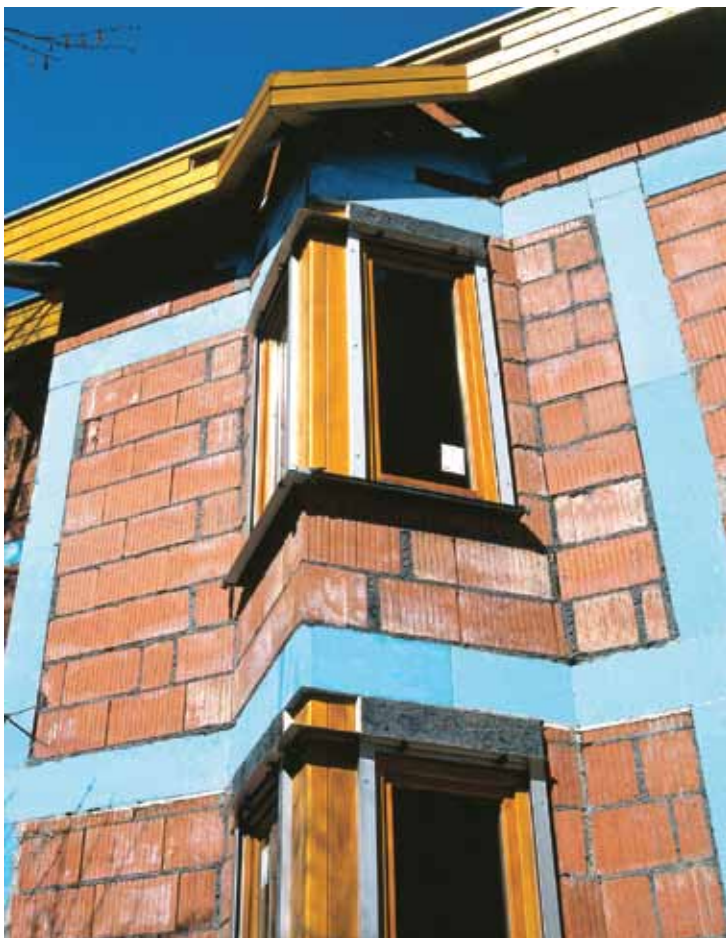

Thermal bridges, columns and beams where structure materials with different thermal conductivity are connected to one another, intersect or mingle are places where heat transfer is more compared to general structure. Particularly on the concrete sections of structures, in case structure elements such as column, beam, girder, headpiece, floor area cannot be insulated externally, there appears a thermal bridge. The insulation obligation of thermal bridges is not because of merely energy loss.

Thermal bridges that are not insulated have an adverse effect on the comfort in the room and internal surface temperature, which may also cause some other problems as condensation, mould, moisture, cracks... etc. As a result, proper projects of thermal bridges and their appropriate insulation provide significant benefits.

1d- Curtain wall Insulation

External insulation is considered the most appropriate system in terms of structure physics in curtain wall systems. It covers the building like a jacket and doesn't leave cold bridge while also preventing the stresses and cracks that may occur because of temperature losses and keeping the construction continuously dry thanks to air-conditioning. In case the heating system is turned off for a short time (at nights), it is prevented that internal setting temperatures fall down. This is a significant aspect for buildings that are continuously used with short breaks, such as office or school.

It has a great importance in multi-storey structures where curtain wall system is used, in creating the appropriate physical setting in terms of thermal comfort and in artificial systems like air conditioning, cooling – heating. Thermal insulation becomes very significant in order to provide the optimal performance in heat control, ensure internal climatic comfort conditions and air conditioning systems to work properly. Following thermal insulation in curtain walls, the sides can be coated with glass, aluminum, marble or concrete precast elements or a material called siding, which is produced from PVC.

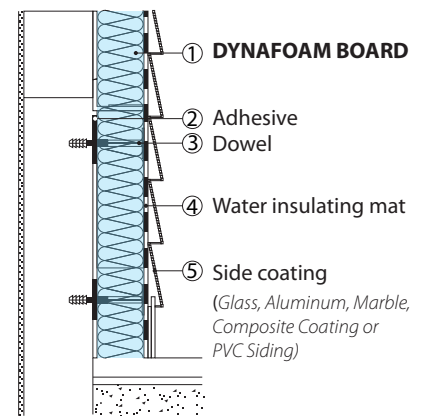

1e- Cavity Wall Thermal Insulation

Dynafoam Board XPS thermal insulation panels can be applied in two ways as open or closed. In open cavity wall application, Dynafoam Board XPS panels should be fixed to the wall surface inside and the open space should be left between the external wall and panels.

In the closed cavity wall application, Dynafoam Board XPS panels stick to the external wall surface and the internal wall is built on the panels without leaving any open space. The vapor transition resistance of the external wall should be low in this application. Dynafoam Board XPS panels don't collapse, or aren't piled up or fragmented at wall base, or they don't cause thermal bridges by forming open spaces.

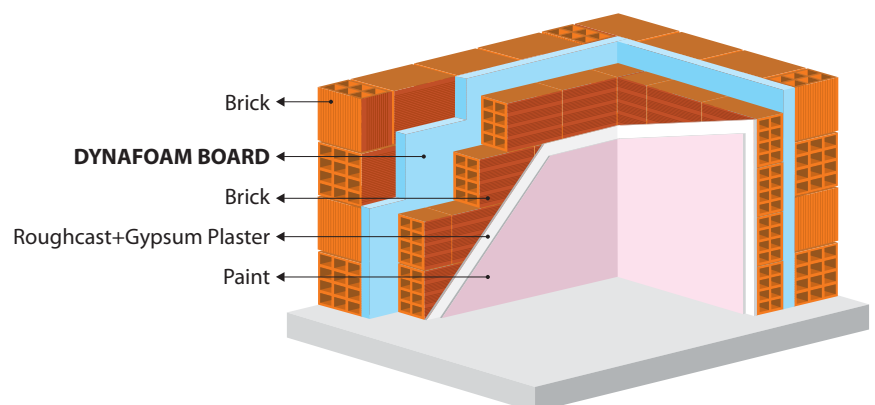

2- ROOF THERMAL INSULATION

2a- Thermal Insulation in Terrace Roofs

In old systems, water insulation mat is on the thermal insulation material on terrace roof and for the purpose of preventing condensation risk under water insulation mat, vapor barrier layer is applied on the floor surface. In reverse terrace roof detail, water insulation mat is directly applied on floor surface and thermal insulation happens to be over water insulation, protecting insulation from UV rays, thermal stresses and mechanical strikes and causing it to have long life. Therefore, there is no need to apply an additional vapor barrier layer and pour protective concrete. The insulation cost is low and application time is short and easy.

In the non-trafficable flat roof application, after pouring slope alum on floor, bitumen emulsion coating application is made. Following the double bitumen water insulation coat, Dynafoam Board XPS thermal insulation panels are laid freely. Care should be given to place the panels on the joints properly. A filter element and a cover that functions as separating pad is laid on the Dynafoam Board XPS thermal insulation panels. In order to make weight and reflect sunlight, pebbles are put on the pad.



Photo 1

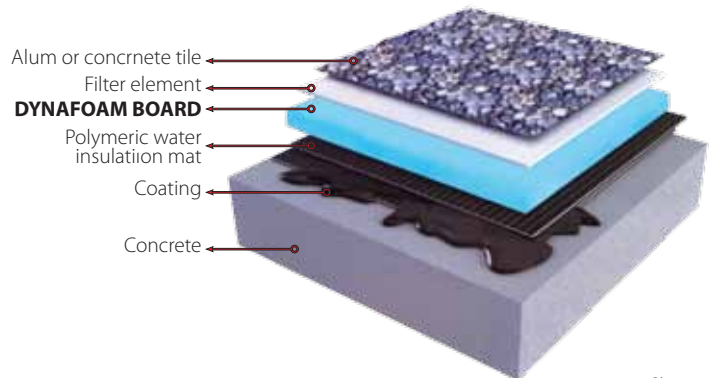

Photo 2

Trafficable terraces on the roof: All layers from concrete floors to surface coating are applied as it is in non-trafficable flat roof application. Slope alum is poured on concrete floor and additional bitumen emulsion coating is applied. Double bitumen water insulation coat sticks to the surface and Dynafoam Board insulation panels are laid freely. In this application, care should be given in order to make the slope concrete in a slope that is not felt such as 2%. Moreover, the first layer water insulation cover should be raised up to parapets and the last layer coat should cover all niches. Concrete tiles on the plastic shore should be located on the filter element in order for the floor coating to be removed easily and without damaging the system when repair and maintenance is needed (Photo 2).

Application on garage roof terraces is the same as the one in non-trafficable flat roof. It is recommended that in terms of load bearing, slope concrete is equipped with normal pebbles with reinforced concrete instead of light pebbles. Depending on the desire, coating can be made or leveling screed is left.

Application on garden terrace roofs is the same as non-trafficable flat roof application. One layer of filter element on pebbles layer and plant soil on that layer are laid to complete the application (Photo 1).

2b- Thermal Insulation on Jerkin-head Roofs

Thermal Insulation over Roof Floor

Applying Dynafoam Board XPS extruded polystyrene panels by placing them on the roof board makes it possible to project the garret and the wooden structure (rafters) in a way that they are seen inside. In this case, the roof board applied on the rafters or OSB panels become more aesthetic with a decorative wooden view inside.

Bitumen water insulation membrane applied on roof board or OSB panel functions as a vapor barrier under the insulation panels and in the warm side apart from its water insulation function. Another solution is to directly lay vapor-permeable water insulation coat on thermal insulation. According to condensation calculations, a vapor equalizer can be placed if needed under thermal insulation in order to prevent air tightness although generally not needed.

The Dynafoam Board XPS Panels, which are supported with an eaves plate at the equal height with the thickness of insulation starting from eaves, are placed without forming thermal bridges and in a way that they are tightly connected. Dynafoam Board XPS panels are attached to roof board by using special stop member in order to prevent flying.

The final layer coating needs to be done without being left under UV rays for a long time.

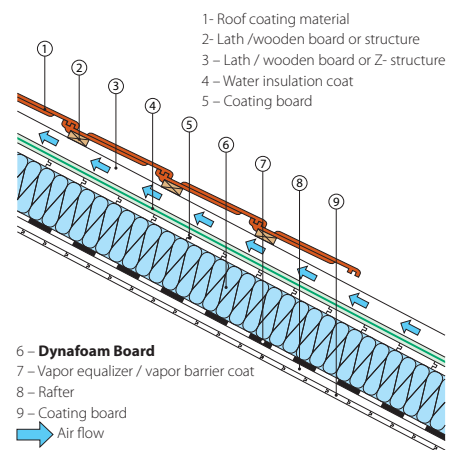

Insulation between or under rafter

In case roof space is used and when rafters are required to be coated aesthetically without being seen under roof space, Dynafoam Board XPS Panels can be fitted below between the rafters and insulation can be done in jerkin-head roofs. Thermal bridges that will occur on the rafter points can be ignored as long as they are wooden rafters. Yet, thermal bridges on steel construction rafters must be insulated.

Insulation over rafter

Water inhibiting coating is placed on thermal insulation and wooden boards are placed on it in the direction that will ensure water spill and wooden boards on which bricks are placed, are laid on them in the eaves direction. Dynafoam Board XPS Thermal Insulation can be permanent under the wooden boards and also they can be placed without leaving any space in between. Leaving space in parallel to slope on the roof level is useful to remove water that can leak between the tiles. In case there is the risk of condensation, vapor barrier coating should be used in the inner side of thermal insulation.



3- FOUNDATION INSULATION

The foundation wall represents the wall and floor areas of the building that contacts with soil. The basic principle in foundation wall insulation is that thermal insulation frames the structure externally. The external insulation of foundation walls reduces heat losses and extends the building life by protecting the basic structure against external effects with a good water insulation.

3a- Concrete Shear Insulation

The advantage of external insulation on foundation wall is that it covers the building without forming a thermal bridge and protects the water insulation membrane from mechanical damage. It is beneficial that external insulation is made on not heated volumes with soil contact. If there is a need for a change in the future, it is significant because it doesn't require insulation work again to use energy efficiently together with comfort conditions.

3b- Thermal Insulation under the Floor Concrete

In order to prevent heat losses that may occur from the floor for energy saving, comfort and protection of the building, a continuous and reliable thermal insulation should be made. Without being dependent on the condition of a current building or any structure whose construction is ongoing, Dynafoam Board XPS can be located on or under the floor concrete. However, the floor structures where insulation is used under floor concrete are exposed to some loads. For instance, service loads (forklift, truck..etc.), static and dynamic loads and loads during the construction phase of a building. Insulation panels used in foundation walls and floors should resist these loads and these aspects of Dynafoam Board XPS panels are at maximum.

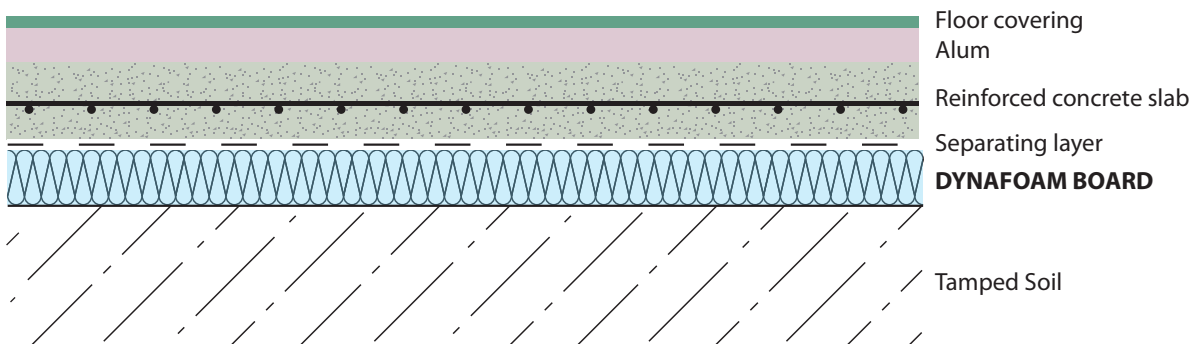

Dynafoam Board XPS thermal insulation panels can be used under the floor coverings for the below listed application areas:

- Floor concrete between continuous footings,
- Load bearing Concrete Foundation (i.e. Slab foundation),
- Floor coverings for Industrial purposes; such as the weight of high shelves, forklift and truck traffic,
- Air vehicle hangars,
- Residence and office buildings.

4- SPECIAL APPLICATIONS

4a- Cold Storage Thermal Insulation

Cooling is a pretty more costly process than heating. An effective thermal insulation and vapor barrier used in a proper place are significant for cold storages to function properly and economically. The technical and hygiene standards determined for cold storage are quite high. For 30 years, XPS products have been used in cold room and cold storage thermal insulation in Europe. With an insulation layer in correct thickness, Dynafoam Board XPS panels provide permanent and reliable solution and minimum energy consumption.

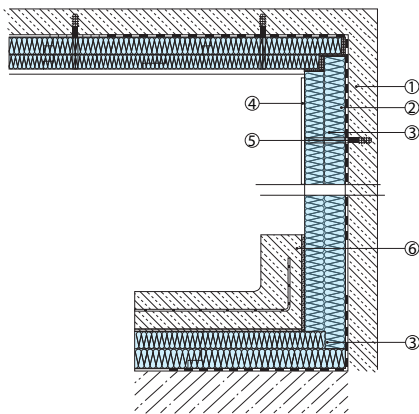

- 1- External wall (Ferro-concrete, lightweight concrete etc.)
- 2- Polymer bitumen vapor barrier
- 3- **DYNAFOAM BOARD**
- 4- Glass-fiber mesh + plaster + coating
- 5- Wall plug
- 6- Ferroconcrete covering

4b- Thermal Insulation under Parquet

DYNAFOAM-SS Polystyrene Thermal Insulation Panels are used under parquet, on internal walls, under wallpapers and under floor coverings as ceramics and alum. Based on thickness, it contributes to thermal insulation while also increasing the lifetime of floor coverings as laminate and parquet that are sensitive to humidity and moisture.

Aluminum foil coated Panel

DYNAFOAM-AL is produced in order to increase the performance of desert panels more. Thanks to this combined product, the ideal insulation value is provided and thanks to the aluminum foil coated on it, the present humidity is prevented successfully. Aluminum foil also increases insulation performance to the top level with the saving provided through radiation.



Product Dimensions

THICKNESS (mm)	PANEL SIZES	NUMBER OF PANELS	AMOUNT OF PACKAGES	CRACTERISTICS
3	80X125 cm.	50 pcs.	50 m ²	SS -AL
4	80X125 cm.	35 pcs.	35 m ²	SS -AL
5	80X125 cm.	25 pcs.	25 m ²	SS -AL
6	80X125 cm.	25 pcs.	25 m ²	SS -AL
8	80X125 cm.	20 pcs.	20 m ²	SS -AL
9	80X125 cm.	15 pcs.	15 m ²	SS -AL

* Manufactured blue as standard.

WHY SHOULD DYNAFOAM BOARD XPS THERMAL INSULATION PANELS BE USED?

Wall Insulation

- * They don't get old and lose their properties in time.
- * Provide continuous thermal insulation during building life.
- * Do not require vapor barrier.
- * Prevent swellings, mould growth and spalling on walls
- * No crumbling or diminishing
- * No leakage.
- * Ensure saving in the area of use since they are used thinner than the known thermal insulations.
- * do not cause thermal bridges.
- * Ensure thermal saving at a level of up to 50 %.
- * Reduce initial investment costs suggested for plumbing since less heating / cooling devices will be used.
- * With less fuel consumption, they help prevent air pollution and save fuel.

Roofs and terraces

- * Protects water insulation that is the most sensitive layer of roof from any kind of effects,
- * Removes the need for vapor barrier, steam equalizer, separating layer and protective alum and the costs of these
- * Easy and practical implementation.
- * Terrace detail is extremely suitable to building physics.
- * The building shows insulation performance for lifetime
- * Cost of maintenance is less compared to other materials
- * Terrace provides easy water test and thus possible errors are prevented even at the process of building.
- * Each point in locations is heated up fast and equally.

Insulation of Foundation

- * Prevents and restrains water and humidity.
- * Durable to loads and strikes and doesn't smashed; saves the costs of protection walls.
- * Easy and practical to assemble.
- * Ensures thermal insulation that has continuous effect
- * More economical and cheaper than protection wall materials (brick, briquette).









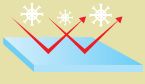

Tecnicl Characteristics

Related Standard

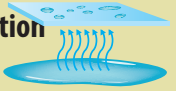
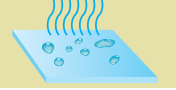
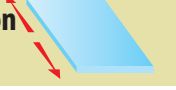

DYNAFOAM[®] BOARD

Density (kg/m³) 	TS EN 1602	22-26	26-32
Working Temperature 		-50 °C +75 °C	
Thermal Conductivity Coefficient -λ (W/m²·k) 	TS EN 12667	λ < 0,030 ± %5	
Fire Resistance 	TS EN 13501-1	E CLASS	
Compression Strength CS (10Y) 	TS EN 926	≥ 200 kPa	≥ 300 kPa
Long Term Water Absorption with Total Immersion 	TS EN 12087	WL (T) ≤ 1,5 %	
Long Term Water Absorption through diffusion 	TS EN 12088	WD (V)5 5 %	
Vapor Diffusion Coefficient (μ) 	TS EN 12086	100 - 200	
Linear Thermal Expansion Coefficient (mm/m²·k) 	TS EN 1604	<0,07	
Capillarity		Non	
Storage	Keep away from sunlight and flame source. Do not store in closed areas that are not air-conditioned well.		
Environmental Effect 	Dynafoam Board XPS Thermal Insulation products do not include heavy metals as asbestos, lead, mercury etc. and CFC and HCFC gases. They don't have harmful effect on ozone layer. They are 100% recyclable.		

* The technical values of Dynafoam Board given above can be changed for improvement purposes.

Product Dimensions

THICKNESS (mm)	PANEL SIZES (mm)		NUMBER OF PANELS	AMOUNT OF PACKAGES			
	PLAIN / ROUGH SLOTTED / PATTERNED	ROUGH		PLAIN / ROUGH SLOTTED / PATTERNED		ROUGH	
20	600x1250	600x2650	20	0,300 m ³	15,00 m ²	0,6360 m ³	31,80 m ²
30	600x1250	600x2650	14	0,315 m ³	10,50 m ²	0,6678 m ³	22,26 m ²
40	600x1250	600x2650	10	0,300 m ³	7,50 m ²	0,6360 m ³	15,90 m ²
50	600x1250	600x2650	8	0,300 m ³	6,00 m ²	0,6360 m ³	12,72 m ²
60	600x1250	600x2650	7	0,315 m ³	5,25 m ²	0,6678 m ³	11,13 m ²
70	600x1250	600x2650	6	0,315 m ³	4,50 m ²	0,6678 m ³	9,54 m ²
80	600x1250	600x2650	5	0,300 m ³	3,75 m ²	0,6360 m ³	7,95 m ²

* Our products are manufactured as lamp connected as a standard. Should you have demands out of standards, please contact with our sales representative.

Tasarım & Baskı:
Güney
Reklamcılık ve Tanıtım Hizmetleri
Basım Tarihi: 21-11-2011



ISO 9001
BUREAU VERITAS
Certification



ISO 14001
BUREAU VERITAS
Certification



dinamik
A dynamic solution in insulation

DİNAMİK ISI ve MAKİNA SANAYİ TİC. DAĞ. ve PAZ. LTD. ŞTİ.

GENEL MÜDÜRLÜK: 1203 / 4 Sokak No: 1 / A Yenişehir - İzmir - TÜRKİYE Tel.: 0.232.449 12 50 (pbx) Faks: 0.232.449 01 34 e-mail: dinamik@dinamik-izmir.com

FABRİKA: Turan Mah. Tire Organize Sanayi Bölgesi Tire -İZMİR/TÜRKİYE Tel.: 0.232.513 51 36 Faks: 0.232.513 51 38

İSTANBUL BÖLGE MÜDÜRLÜĞÜ: Atatürk Cad. Eflatun Sok. No: 2 Y. Dudullu Ümraniye - İSTANBUL Tel.: 0 216 364 63 68 Fax: 0 216 364 63 69

www.dinamik-izmir.com